

MILO in2CRICKET CUP SUPER 8s REGISTRATION 2011



CRICKET
VICTORIA



WELCOME MESSAGE

Cricket Victoria have been conducting this modified cricket competition across the state since 1998. In 2010, over 300 secondary schools participated with 505 boys and 324 girls' teams entered in the MILO in2CRICKET Super 8s state-wide competition.

As part of our on-going commitment to providing quality opportunities to play cricket in schools, Cricket Victoria would like to invite your school to be involved in the 2011 MILO in2CRICKET Cup Super 8s state-wide competition. The Super 8s format has easy to understand rules that encourage team work and communication and aims to maximise the participation of all players. And best of all – entry is FREE!

The MILO in2CRICKET Cup Super 8's state-wide competition has four separate divisions - a Year 7/8 boys and girls section and a Year 9/10 boys and girls section.

This booklet has been sent to all secondary schools in Victoria and covers the details regarding this year's competition including;

- Explanation about how MILO Super 8s operates;
- MILO Super 8s venues & dates listing;
- Details of the registration procedure;
- Contact details for Cricket Victoria staff.

Schools that enter the MILO in2CRICKET Cup Super 8s competition for the first time are encouraged to request a FREE clinic from a Cricket Victoria qualified coach prior to the competition (located in the on-line registration form). This clinic is aimed to teach the rules of the game, ground layout, strategies and tips.

With cricket participation consistently growing and with the worldwide interest in Twenty20 cricket, I encourage all schools to jump on board. I wish every school that enters the MILO in2CRICKET Cup Super 8s competition for 2011 the best of luck and I look forward to watching the State Final on the mighty MCG.

John Watkin
GENERAL MANAGER, GAME DEVELOPMENT, CRICKET VICTORIA



ABOUT MILO SUPER 8S

The MILO in2CRICKET Cup Super 8s state-wide competition is a modified one-day cricket competition for boys and girls from Years 7 to 10. Schools attend their local regional carnival (see pages 4 & 5 for dates and locations) and compete in a round robin competition against other local schools.

MILO in2CRICKET Cup Super 8s maximises participation for all participants in an action packed 16 over game (8 overs per team) that requires only 45–50 minutes to complete. A regional carnival typically runs along the following timeline:

- 9:30am: Schools arrive at local venue
- 9:45am: School briefing (rules refresher)
- 10:00am: Round 1
- 11:00am: Round 2
- 12:00pm: Round 3
- 1:00pm: Finals
- 2:00pm: Presentations
- 2:15: Schools depart

(Please note: some carnivals may vary slightly from this schedule)

The winning girls and boys team from the various metropolitan and regional carnivals will be offered the opportunity to participate in a regional final. There will be one regional final day held for Eastern schools, and one for Western schools. Venues for these finals will be confirmed at a later date. The winning schools at these carnivals will progress through to the State Final at the MCG in December.

REGIONAL AND STATE FINALS

Year 9/10 Super 8s REGIONAL Final: Wednesday 9 November 2011

The Winning boys and girls teams from the regional final will qualify to play the State Grand Final at the MCG in **December (date to be finalised)**.

Year 7/8 Super 8s REGIONAL Final: Wednesday 16 November 2011

The winning boys and girls teams from the regional final will qualify to play the State Grand Final at the MCG in **December (date to be finalised)**.

*Please Note - State and Regional Finals may change due to fixturing. This is beyond Cricket Victoria's control. All schools will be notified if this occurs

REGISTRATION

Registrations for the 2011 carnivals will again be taken on-line. Schools are asked to complete the registration form on the Cricket Victoria website. Schools entering for the first time are encouraged to take up the offer of a FREE school clinic. Teachers are also offered the opportunity to join the MILO in2CRICKET School Ambassador Program.

http://www.cricketvictoria.com.au/page/super_8s.html

Registrations for all of the carnivals close on the following dates;

Year 7/8 – Friday 7th October 2011

Year 9/10 – Friday 23rd September 2011

***Please note that after these dates Cricket Victoria may not be able to accommodate your school at its preferred venue or provide a clinic.*

Registration is on a first come, first served basis with preference given to schools in the municipality of the carnival venue. Once the capacity of a carnival has been reached, it will be removed from the on-line registration form. Schools will be sent a confirmation email within 7 days of registering. Please contact Cricket Victoria if this does not occur.

If you have any queries regarding the information contained in this booklet, please contact Ryan Batchelder (Game Development officer) at Cricket Victoria on 9653 1155 or email rbatchelder@cricketvictoria.com.au.



YEAR 7/8 REGIONAL CARNIVALS

YEAR 9/10 REGIONAL CARNIVALS

Cricket Victoria will be holding MILO in2CRICKET Cup Year 7/8 Super 8s Regional Carnivals at the following venues on the following dates.

DATES & VENUES			
Robinvale	27 October 2011	Robinswood Ovals	1
Horsham	9 November 2011	Dudley Cornell Park	2
Warrnambool	9 November 2011	Mack & Walter Ovals	2
Hamilton	10 November 2011	Pedrina Park	2
Gisborne	3 November 2011	Dixon Field	3
Ballarat	4 November 2011	Victoria Park	3
Geelong	25 October 2011	Kardinia Park & West Kardinia	4
Shepparton	20 September 2011	John McEwen Reserve	5
Bendigo	21 October 2011	Biescher Park	5
Wangaratta	25 October 2011	Bahr Reserve	6
Bairnsdale	27 October 2011	Lucknow Recreation Reserve	7
Drouin	7 November 2011	Moe Racecourse	7
Sale	10 November 2011	Stephenson Park	7
Mt Eliza	10 November 2011	Emil Madsen Reserve	8
Werribee	13 October 2011	Soldiers Reserve	9
Melton	18 October 2011	Blackwood Drive Reserve	9
Bundoora	2 November 2011	Yulong Reserve	11
Mulgrave	4 November 2011	Mulgrave Reserve	12
Balwyn	27 October 2011	Hislop Park	13
Croydon	28 October 2011	Silcock Reserve	14
Cranbourne	3 November 2011	Casey Fields	16
East/West Final	16 November 2011	TBA	ALL
State Final	TBA	MCG	

Cricket Victoria will be holding MILO in2CRICKET Cup Year 9/10 Super 8s Regional Carnivals at the following venues on the following dates.

DATES & VENUES			
Ouyen	18 October 2011	Blackburn Park	1
Hamilton	18 October 2011	Pedrina Park	2
Horsham	19 October 2011	Dudley Cornell Park	2
Warrnambool	27 October 2011	Mack & Walter Ovals	2
Geelong	18 October 2011	Kardinia Park & West Kardinia	4
Bendigo	14 October 2011	Biescher Park	5
Wangaratta	25 October 2011	Bahr Reserve	6
Bairnsdale	18 October 2011	Lucknow Reserve	7
Mt Eliza	19 October 2011	Emil Madsen Reserve	8
Melton	10 October 2011	MacPherson Park	9
Bundoora	3 November 2011	Yulong Reserve	11
Balwyn	18 October 2011	Hislop Reserve	13
Croydon	25 October 2011	Silcock Reserve	14
Cranbourne	25 October 2011	Casey Fields	16
East/West Final	9 November 2011	TBA	ALL
State Final	TBA	MCG	ALL

NB: All venue locations and times will be confirmed by email.

Please Note: All venue locations and times will be confirmed via email prior to the carnival. Some locations may be changed due to factors beyond the control of Cricket Victoria.

THE GAME

1. Each game is played between two teams with a minimum of eight players. Substitutes may be used in any combination providing that no more than eight individuals bat and eight individuals bowl. Only eight fielders are permitted on the field at any one time.
2. At regional carnivals, teams will play a minimum of three round robin games. Finals will be played to decide the winning boys and girls teams.
3. A coin toss is used to decide which team bats first in each game.

EQUIPMENT

1. Wooden or plastic bats may be used by batters.
2. Kookaburra 'Super Softa balls' will be used at regional carnivals. These are provided by Cricket Victoria
3. All batters must wear pads and gloves.
4. It is strongly recommended that the batters and wicket-keeper wears a helmet with a grill.

BATTING

1. Eight batters are put in pairs numbered 1 – 4 by the teacher / coach / captain. Each pair will bat together for 2 overs (12 balls).

Pairs remain batting irrespective of the number of times they are dismissed, until they have batted for 2 overs (12 balls). Batters swap ends at the end of each over (6 balls).

2. Players can be 'out' in the following ways: 'bowled', 'caught', 'run out', 'stumped', 'hit wicket' or 'leg before wicket' (L.B.W). A batter can only be out L.B.W. when they do not offer a shot and the ball is definitely going to hit the stumps.
3. The only penalty for being 'out' is that players swap ends (this does not apply to 'run out') and the bowling team receives 5 bonus runs to their total score.
4. The next batting pair must be ready to bat immediately following the previous pair's innings.
5. Once all four pairs have batted for two overs the two teams swap roles.

BOWLING

1. Eight players must bowl and wicket-keep for one over each (there is no designated wicket-keeper). One partner bowls whilst the other wicket-keeps (the wicket-keeper must field behind the stumps at the batter's end). At the end of the over (6 balls) the partners swap roles.
2. Bowlers are limited to eight metre run-ups. The maximum run up will be marked by a white line.
3. All overs are bowled from the same end. At the end of each over the batters swap ends.
4. There will be a maximum of 6 deliveries in each over. 'No balls' are not re-bowled except for the final over of the innings, which must contain 6 legitimate balls.
5. **STATE FINAL RULE:** At the State Final the first three balls of each over must be bowled 'over-arm'. The second three balls can be bowled 'under-arm' if the bowler is having difficulty over-arm. When bowling under arm the ball is only allowed to bounce once.

NO BALLS

1. A ball that bounces over shoulder height when the batter is in a normal batting stance shall be called a 'no ball'. Any ball that is a full toss above waist height shall also be deemed a 'no ball'.
2. At the batter's end there will be two plastic cones placed parallel to the stumps, 120 cms from the middle stump. Any ball that passes outside this area shall be deemed a 'no ball'. (See Diagram A).
3. Two runs are awarded to the batting team for every 'no ball' bowled.
4. Any over-arm delivery that bounces more than once or rolls along the ground, shall be deemed a fair delivery (unless the bowler is deliberately rolling it along the ground to obviously gain an advantage). THE UMPIRE MAY DECIDE TO RE-BOWL DELIVERIES IF CONSIDERED UNFAIR.

SCORESHEET YR 9/10 BOYS

SCORESHEET YR 9/10 BOYS

Vs

Round: 1 2 3 Final (please circle)

Mark wicket taken with an X / Balls not scored from shown with a dot
Runs scored from hits into the double zone are doubled / Wides and no balls = 2 runs

FIRST BATTING TEAM:

BATTER	RUNS SCORED BY BATTER (PROGRESSIVE SCORE)
1.	1 2 3 4 5 6 7 8 9 10 11 12 13 14 15 16 17 18 19 20 21 22 23 24 25
2.	1 2 3 4 5 6 7 8 9 10 11 12 13 14 15 16 17 18 19 20 21 22 23 24 25
3.	1 2 3 4 5 6 7 8 9 10 11 12 13 14 15 16 17 18 19 20 21 22 23 24 25
4.	1 2 3 4 5 6 7 8 9 10 11 12 13 14 15 16 17 18 19 20 21 22 23 24 25
5.	1 2 3 4 5 6 7 8 9 10 11 12 13 14 15 16 17 18 19 20 21 22 23 24 25
6.	1 2 3 4 5 6 7 8 9 10 11 12 13 14 15 16 17 18 19 20 21 22 23 24 25
7.	1 2 3 4 5 6 7 8 9 10 11 12 13 14 15 16 17 18 19 20 21 22 23 24 25
8.	1 2 3 4 5 6 7 8 9 10 11 12 13 14 15 16 17 18 19 20 21 22 23 24 25
Returning Retired Batter	
	26 27 28 29 30 31 32 33 34 35 36 37 38 39 40 41 42 43 44 45 46 47
	26 27 28 29 30 31 32 33 34 35 36 37 38 39 40 41 42 43 44 45 46 47

Batters retire once they score 25 runs. They can return to bat once all other batters are out or also retired.

BOWLER	BALLS BOWLED - SCORE PER OVER								PROGRESSIVE		
	1	2	3	4	5	6	RUNS	WICKETS	RUNS	WICKETS	
1.											
2.											
3.											
4.											
5.											
6.											
7.											
8.											
									RUNS		
									TOTAL SCORE		

SECOND BATTING TEAM:

BATTER	RUNS SCORED BY BATTER (PROGRESSIVE SCORE)
1.	1 2 3 4 5 6 7 8 9 10 11 12 13 14 15 16 17 18 19 20 21 22 23 24 25
2.	1 2 3 4 5 6 7 8 9 10 11 12 13 14 15 16 17 18 19 20 21 22 23 24 25
3.	1 2 3 4 5 6 7 8 9 10 11 12 13 14 15 16 17 18 19 20 21 22 23 24 25
4.	1 2 3 4 5 6 7 8 9 10 11 12 13 14 15 16 17 18 19 20 21 22 23 24 25
5.	1 2 3 4 5 6 7 8 9 10 11 12 13 14 15 16 17 18 19 20 21 22 23 24 25
6.	1 2 3 4 5 6 7 8 9 10 11 12 13 14 15 16 17 18 19 20 21 22 23 24 25
7.	1 2 3 4 5 6 7 8 9 10 11 12 13 14 15 16 17 18 19 20 21 22 23 24 25
8.	1 2 3 4 5 6 7 8 9 10 11 12 13 14 15 16 17 18 19 20 21 22 23 24 25
Returning Retired Batter	
	26 27 28 29 30 31 32 33 34 35 36 37 38 39 40 41 42 43 44 45 46 47
	26 27 28 29 30 31 32 33 34 35 36 37 38 39 40 41 42 43 44 45 46 47

Batters retire once they score 25 runs. They can return to bat once all other batters are out or also retired.

BOWLER	BALLS BOWLED - SCORE PER OVER								PROGRESSIVE		
	1	2	3	4	5	6	RUNS	WICKETS	RUNS	WICKETS	
1.											
2.											
3.											
4.											
5.											
6.											
7.											
8.											
									RUNS		
									TOTAL SCORE		

SCORES VERIFIED: TEAM 1: TEAM 2:

MATCH WON BY:

BOWLING

1. Eight overs must be bowled by each team. Each player is to bowl one over. The team can decide to have a 'designated wicket-keeper' who does not bowl. The eighth over can be bowled by a player who has previously bowled one over.
2. Bowlers are limited to eight metre run-ups. The maximum run up will be marked by a white line.
3. All overs are bowled from the same end. At the end of each over the batters swap ends.
4. There will be a maximum of 6 deliveries in each over. 'No balls' are not re-bowled except for the final over of the innings, which must contain 6 legitimate balls.

NO BALLS

1. A ball that bounces over shoulder height when the batter is in a normal batting stance shall be called a 'no ball'. Any ball that is a full toss above waist height shall also be deemed a 'no ball'.
2. At the batter's end there will be two plastic cones parallel to the stumps, 120 cms from the middle stump. Any ball that passes outside this area shall be deemed a 'no ball'. (See Diagram A).
3. Two runs are awarded to the batting team for every 'no ball' bowled.
4. Any over-arm delivery that bounces more than once or rolls along the ground, shall be deemed a fair delivery (unless the bowler is deliberately rolling it along the ground to obviously gain an advantage). THE UMPIRE MAY DECIDE TO RE-BOWL DELIVERIES IF CONSIDERED UNFAIR.

FREE HIT

1. If a 'no ball' is bowled the next ball is a 'free hit'. Batters can only be 'out' 'run out' from a 'free hit'. They can't be 'bowled', 'hit wicket' 'leg before wicket' or 'stumped'.
2. If a batter hits a delivery that is a 'no ball', they score 2 plus whatever runs are scored from the shot. The next ball remains a FREE HIT BALL. If the batter decides to leave or misses a delivery that is deemed a 'no ball', they score 2 runs for the 'no ball' and the next ball is a free hit.

3. If a batter decides to hit a delivery (and connects) that is wide of the 'no ball' markers, they only score runs made from that shot and they may be caught out.

If the batter decides to leave or misses a wide delivery, they score 2 runs for the 'no ball' plus whatever runs they score from the next ball which is a free hit.

FIELDING

1. At the moment of delivery, no players may field closer than 10 metres from the bat (except for the wicketkeeper or slip fielders. See Diagram B).
2. No more than three players can field in the 'double zone' at the time of delivery.
3. Fielders can be interchanged at the conclusion of each batting pair. If a fielder is injured a substitute may take his/her place and fulfil all requirements of that player.

SCORING

1. The Year 9/10 Boys Super 8s scoresheet can be found in the middle pages of the book. Note the Year 9/10 Super 8s scoresheet is different to the Kanga 8s, Year 7/8 & Year 9/10 Girls Super 8s scoresheet.
2. All runs and extras are scored according to the rules of cricket with the following exceptions.
3. A 'no ball' is scored as 2 runs to the batting side plus whatever runs are scored. The next ball is a 'free hit', see the rules for a 'free hit'.
4. Any run scored off the bat into the 'Double Zone' will be doubled. The 'Double Zone' is any area behind the stumps at the bowler's end (see Diagram B & C). A ball hit along the ground to the boundary in this zone, is credited with **8** runs. If the ball is hit over the boundary on the full in the 'Double Zone', then **12** runs are scored. (Note: 2 runs for a 'no ball' does not become 4 if it is hit into the 'Double Zone').
5. Teachers, parents or helpers from both teams will be responsible for scoring at all games. Teachers, parents, helpers or local cricket club members will also help umpire regional carnivals.

DIAGRAM A

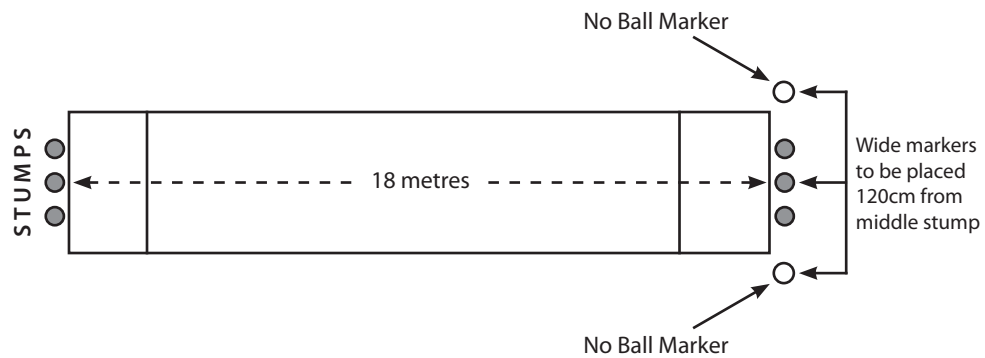

DIAGRAM B

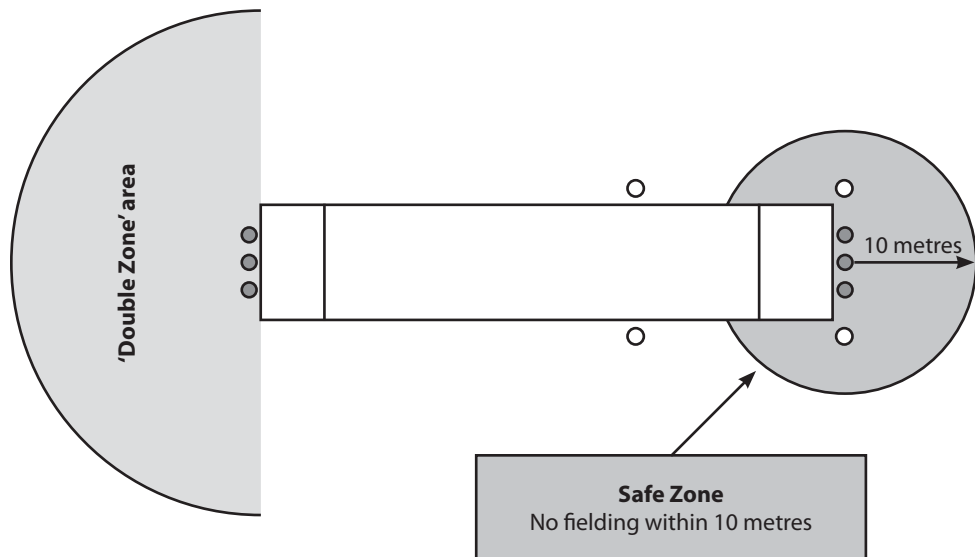
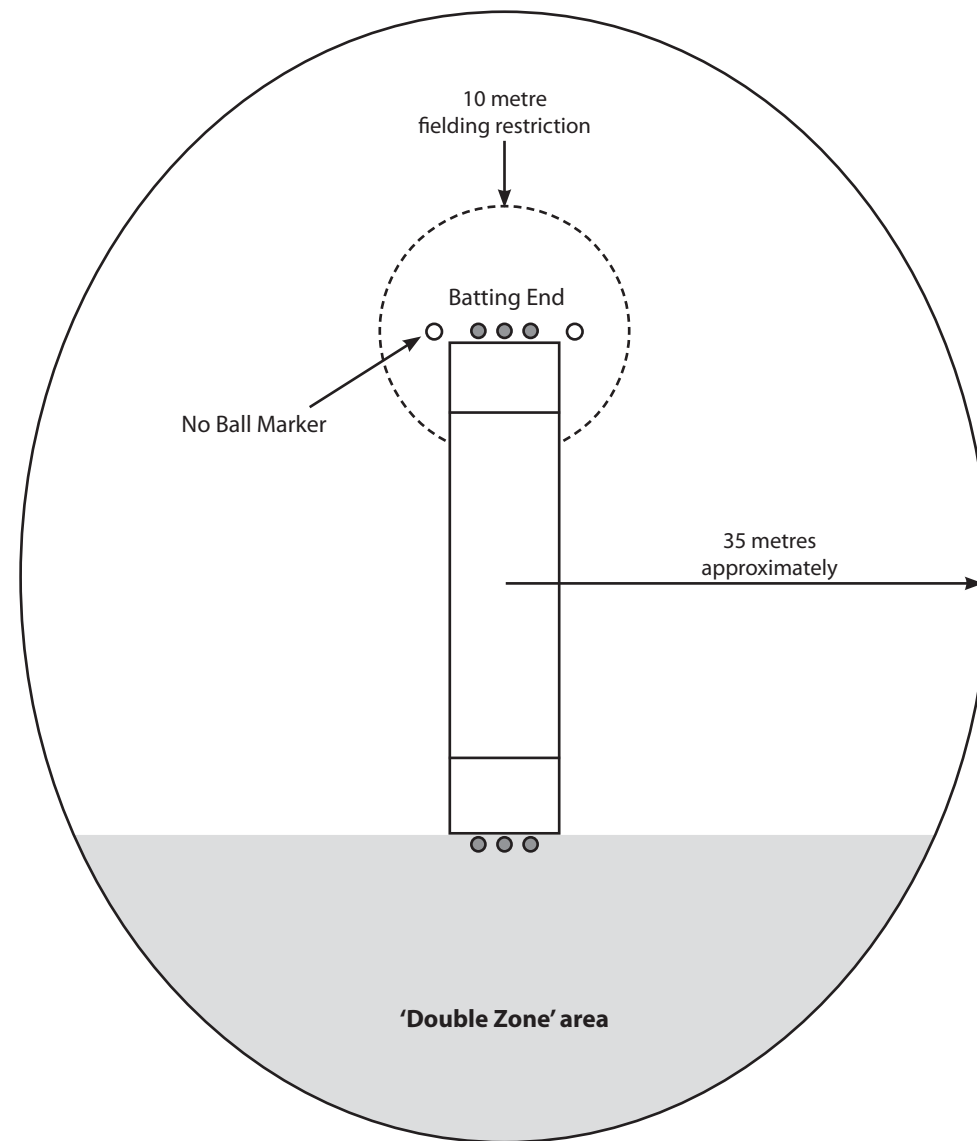

DIAGRAM C



Q. How many teams can my school enter?

Every school has the option of entering up to 3 boys and 3 girls teams per carnival.

Q. Can I enter a mixed (boys & girls) teams?

A. Yes, a number of schools enter mixed teams when they do not have enough students for a separate boys and girls team. Mixed teams will usually compete in the boys division unless the team is composed of more girls than boys.

Q. What equipment does our school need to provide?

A. Schools need to provide bats (plastic or wooden) pads and gloves for their teams. Helmets are recommended but not compulsory. Cricket Victoria will provide all other equipment.

Q. Can students use their own equipment?

A. Yes, students can use their own equipment (bat, pads, gloves, helmets). All equipment should be clearly named and safe for use.

Q. Can more than eight (8) players play per team?

A. The maximum number of players allowed on the field at any one time is eight (8), however a team may choose to have a player who bats and does not bowl and another player who bowls but does not bat, therefore ten (10) players per team. Alternatively players may be 'rostered off' for one of the round robin games. However it is recommended there are no more than ten (10) players per team.

Q. Who scores and umpires at the regional carnivals?

A. Each school is required to umpire and score their games at regional carnivals and state finals. Teachers can organise a parent or an older brother/sister to do this role on the day. Senior students are used by many schools to help organise their teams at carnivals.

Q. Does Cricket Victoria offer travel subsidies for country schools to travel to the State Finals?

A. Yes, details of the subsidies will be outlined to the relevant schools closer to the State Final date. These are generally used to off-set the cost of transport to the MCG.

Q. What do the overall state champion teams win?

A. The winning schools will be awarded with a lap top for their school. There will also be other give-aways on the day as all teams attending the State Final will also win a tour of the MCG (to be taken on the day – either before or after their game).

CONTACT	REGION	#	OFFICE	MOBILE
Ryan Batchelder	Game Development Officer	-	9653 1155	0437 667 356
Andrew Farlie	Mallee Murray	1	5033 0356	0408 321 877
Stephen Field	West Country	2	5577 2672	0417 342 332
Campbell Waring	Central Highlands	3	5332 8696	0427 839 548
Bruce Nunn	Barwon	4	5254 1435	0409 018 096
Travis Colley	North Country	5	5442 6655	0408 562 704
Rhys Miller	North East Country	6		0407 922 414
Rob Wood	Gippsland	7	5662 5293	0408 820 582
Jason Mathers	South East Country	8	5975 0462	0413 888 398
Duncan Harrison	West Metro	9		0428 382 349
Daniel Trevillian	North West Metro	10		0438 650 704
David Hall	Northern Metro	11	9372 9681	0413 840 047
David Bourke	Inner South East Metro	12		0429 414 799
Shane Koop	Inner East Metro	13	9510 8339	0413 840 049
Ryan Batchelder	Outer East Metro	14	9653 1155	0437 667 356
Stuart Clark	South East Metro	15	9553 1363	0409 025 232
Adrian Jones	South Metro	16	9772 2240	0433 574 865

Email: fristinitialsurname@cricketvictoria.com.au eg: rbatchelder@cricketvictoria.com.au



Introduction to Cricket

FREE
online
accreditation

It's easy, online and FREE!

Australian cricket has launched its revolutionary Introduction to Cricket online accreditation course for those who are beginning life as cricket volunteers. The interactive online program tutors candidates in the areas of cricket philosophy, technique and basic principles. The course has been designed to allow candidates the flexibility to stop and save their position within

- What is cricket?
- The role of the coach & umpire
- The skills of cricket
- Risk management
- Basic laws of cricket
- Fundamentals of scoring

the course at any time, affording them the opportunity to complete the program at their own leisure. On completion, you will be accredited by the Australian Sports Commission. You will also become a member of Cricket Coaches Australia for a two-year accreditation period, gaining you discounts on cricket resources and access to the members'-only website.

For more information
www.cricket.com.au/introductiontocricket

GET in2ACTION

GET in2CRICKET

in2 CRICKET
Nestlé
MILO

sign up today

MILO in2CRICKET introduces boys and girls to the game of cricket through fun, action-packed programs and activities. You can join in all the fun at a cricket club, school or community centre nearest you! So get in2ACTION by signing up at www.in2CRICKET.com.au today!

MILO in2CRICKET SCHOOL AMBASSADOR PROGRAM RECOGNISES AND REWARDS A TEACHER IN EACH AUSTRALIAN PRIMARY AND SECONDARY SCHOOL WHO IS COMMITTED TO ENSURE THEIR STUDENTS HAVE EVERY OPPORTUNITY TO GET INVOLVED IN CRICKET. LOG ONTO in2CRICKET.COM.AU FOR MORE INFO

IT'S EASY 2 SIGN UP AT in2CRICKET.COM.AU



**GET in2 ACTION.
GET in2 CRICKET.**

